



KLR 10

Lift Reserve Indicator



Pilot's
Guide

BendixKing

by Honeywell

BendixKing.com

BendixKing by Honeywell

9201-B San Mateo Blvd. NE
Albuquerque, New Mexico 87112

Product Registration

For product registration go to BendixKing.com or call our customer support number below.

Customer Support

US and Canada - 1.855.250.7027

International – 1.602.365.7027

bendixking.com/support

At BendixKing we value your opinion and we are listening. For comments about this guide, please email:

techsupport@bendixking.com

The information contained in this manual is for reference only. If any information contained herein conflicts with similar information contained in the Airplane Flight Manual, the information in the Airplane Flight Manual shall take precedence.

COPYRIGHT NOTICE

© 2013, 2014, BendixKing by Honeywell. All rights reserved.

Reproduction of this publication or any portion thereof by any means without the express written permission of Honeywell International Inc. is prohibited. See Appendix for complete terms and conditions.

KLR 10™

**LIFT RESERVE
INDICATOR**

PILOT'S GUIDE

Revision History and Instructions

Manual KLR 10 Indicator Pilot's Guide

Revision 1

Summary Revisions to various sentences for technical accuracy.
Removed Section 4.2 Honeywell Confidential.

Manual KLR 10 Indicator Pilot's Guide

Revision 0

Summary This is a new release.

Record of Revisions

REVISION NUMBER	REVISION DATE
0	JULY, 2013
1	FEBRUARY, 2014

Table of Contents

<u>Section</u>	<u>Page</u>
1. Introduction	1-1
1.1 Background Information:	1-1
1.2 System Description.....	1-1
1.3 Restrictions and Limitations	1-2
2. KLR 10 Controls	2-1
2.1 Power Up Self Test.....	2-1
2.2 KLR 10 Indicator Main Controls	2-1
2.3 The KLR 10 Display Segments:	2-4
2.4 Display Brightness Calibration	2-7
2.5 Brightness Adjustment when Active	2-8
2.6 In-Flight Calibration Flow Charts	2-8
3. Operation	3-1
3.1 Practice High AOA Flight Regime	3-2
Observed Indications	3-3
3.2 Practice Takeoff and Climb using AOA	3-7
Establish Segments Illuminated	3-8
Fly Practice Takeoffs for Familiarization	3-9
Observed Indications	3-10
3.3 Practice Best Glide speed	3-11
Establish Segments Illuminated	3-11
3.4 Practice Approaches using AOA	3-13
Establish Segments Illuminated	3-14
Fly Practice Approaches for Familiarization.....	3-15
Useful Techniques when using KLR 10 Indicator	3-16
NOTES	3-18
4. Appendix	4-1
4.1 Acronyms and Abbreviations.....	4-1
4.2 Copyright - Notice	4-3

List of Illustrations

<u>Figure</u>	<u>Page</u>
Figure 2-1: KLR-10 Indicator Controls	2-1
Figure 2-2: OAA Setpoint Calibration.....	2-9
Figure 2-3: Cruise Setpoint Calibration.....	2-10

List of Tables

<u>Table</u>	<u>Page</u>
Table 2-1: KLR 10 Indicator Control Switch Features	2-2
Table 2-2: KLR 10 Indicator Segments.....	2-4
Table 3-1: Observed Indications Chart	3-17

1. INTRODUCTION

1.1 BACKGROUND INFORMATION:

The KLR 10 system is primarily designed to improve the pilot's awareness of available lift during operations at high angles of attack (AOA). Additional benefits include identifying or maximizing aircraft performance based on a fixed AOA or a constant CL, such as maximum range, best glide, climbs and approaches.

AOA: **Angle of Attack** is the acute angle between the wing chord line and the relative wind.

CL: **Coefficient of Lift** is a relative measure of an airfoil's lifting capabilities.

CL_{max}: **Coefficient of Lift Maximum** is the AOA which if exceeded will cause the airfoil to stall.

CD: **Coefficient of Drag** is a measure of total drag, induced and parasite drag.

CL/CD: **Coefficient of Lift over Coefficient of Drag** is a ratio between lift and drag.

CL/CD Maximum: The maximum lift-to-drag ratio at which maximum range and maximum glide distance will be found for propeller airplanes.

1.2 SYSTEM DESCRIPTION

The KLR 10 measures pressure at two points from an AOA probe mounted solidly to the wing in reference to the cord of the wing that conveys changing differential pressures, via sense lines, to the KLR 10 IF module. The IF module converts the pressures into an electronic signal that is transmitted to the KLR 10 indicator.

The KLR 10 indicator interprets the signal and turns on the appropriate segments to convey the AOA or lift information to the pilot. In addition to the visual display, the IF module also has an I/O connector that allows connection of the remote audio interface system that provides warning annunciations in the pilot's headset.

The KLR 10 draws a minimal current of less than approximately ¼ amp (250mA) of electrical power. For the system to operate correctly, it must be supplied electrical power within a range of 12 to 28VDC and be calibrated correctly.

The AOA probe must be kept clear of any obstructions and be mounted securely, in clean air flow. The final AOA probe to wing angle will be determined by the amount the bottom of the wing varies from parallel to the cord of the wing. For most aircraft, the starting angle is 50 degrees from the leading edge of the AOA probe mounting plate. The KLR 10 system will adjust for differences within a limited electrical signal range. **AOA Probe angle readjustment may be needed to allow for full scale electronic calibration.**

Probe heat is an option, and if installed, requires less than 8 amps of electrical power at 12 or 24VDC to operate. To extend the life of the probe heat element, it is recommended that the probe heat not be used for prolonged periods while on the ground.

The KLR 10, when properly calibrated in accordance with the BendixKing KLR 10 Installation Manual part number D201305000058, will have an accuracy of $\pm 3\%$ over the full scale of the calibration. This accuracy is maintained over a sideslip range of ± 15 degrees.

1.3 RESTRICTIONS AND LIMITATIONS

The KLR 10 Lift Indicator is non-required and is to be used only as supplemental information to the pilot.

The KLR 10 Lift Indicator may not be used as a substitution for the certified aircraft stall warning system.

No operational credit may be taken for such items as reduced approach speed and shorter landing distances.

2. KLR 10 CONTROLS

2.1 POWER UP SELF TEST

When power is first applied to the KLR 10 (only after ground, OAA and Cruise are fully calibrated per the Installation Manual), the KLR 10 runs through a built in test. During the test, the segments cycle up and then down the display. When the test is complete, the segments turn off and the KLR 10 annunciates "AOA test complete".

2.2 KLR 10 INDICATOR MAIN CONTROLS



Figure 2-1: KLR-10 Indicator Controls

Use the table below for a description of the functionality of the controls in Figure 2-1

Table 2-1: KLR 10 Indicator Control Switch Features

ITEM	CONTROL	FUNCTION
1	Audio "Mute" Amber LED	When the LED is illuminated, audio is muted. When the LED is not illuminated, audio is not muted.
2	Audio "Mute" Toggle Switch	<p>In the UP position, this switch mutes the audio and illuminates the amber LED (1) on the KLR 10 indicator.</p> <p>In the down position, this switch activates the high AOA warning annunciations and the amber LED (1) on the KLR 10 indicator is not illuminated.</p>
3	Calibration Mode Switch	Rotary switch used to enter calibration mode. When the slot is in the vertical position and the brightness mode button is pressed one time, the calibration mode is activated. When the slot is turned to the horizontal position and the brightness mode button is pressed one time, the calibration mode is exited and the KLR 10 unit announces: "Calibration Mode Off".

ITEM	CONTROL	FUNCTION
4	Brightness / MODE Push Button Switch (Multiple Functions)	<p>The Brightness button is the black push button on the lower right corner of the display.</p> <p>The Brightness button has 2 functions:</p> <p>Changes the brightness levels of the colored segments (Quickly push and release to cycle thru 16 brightness levels),</p> <p>Operates as a MODE switch, to enter into and out of OAA and Cruise calibration steps when the calibration rotary switch is vertical. See page 2-7 for more information on how to set the Brightness levels.</p>
5	The "CAL SET" push button	<p>The calibration set push button is the black button located at the bottom right corner and is recessed underneath the front case. The calibration set button is used to enter selected calibration set points (Ground Zero, OAA and Cruise) during the calibration procedure. It can be actuated using a pencil or other small blunt pointer.</p>
6	Display Segments	<p>Multicolored segments that correspond to different angles of attack for the aircraft.</p>
7	Auto Brightness Photo Cell	<p>The photo cell is in the top, middle of the KLR 10 display and automatically detects the ambient light changes which will switch from daytime brightness preset to nighttime brightness presets.</p>

2.3 THE KLR 10 DISPLAY SEGMENTS:



The KLR 10 display has chevron and bar styled LED-driven color-coded segments which, once correctly calibrated in accordance with the BendixKing KLR 10 Installation Manual, part number D201305000058, illuminate corresponding to the AOA of the aircraft. The display will respond to the linear changes of the aircraft's AOA from Cruise, up to Stall and gives a repeatable, instantaneously changing segment representation of that range. The display will illuminate a series of transitional segments from no segments to the **Green Bar**  ("Cruise" indication for the aircraft located at the bottom of the display), and on through to the **flashing Red**







Arrow  (stall indication for the aircraft located at the top of the display).

A correctly calibrated KLR 10 will provide a linear increase in AOA indication as the aircraft slows. The final "Too slow Too slow" alert with flashing red arrow **MUST** be active prior to the actual aerodynamic stall. Ensure during post-calibration testing that the final KLR 10 alert state is displayed prior to any stall indications.

The 10 possible segment combinations are listed below. Every aircraft will correlate the lit segment or combination of segments to the specific aircraft's AOA dynamics, once calibrated. The relationship of when and which combination shows is unique to the aircraft's AOA and can be accurately correlated **ONLY** when in-flight.

Table 2-2: KLR 10 Indicator Segments

SEGMENT	ABBR	CONDITION
	G	Green Bar with no other segments indicates Cruise set point, (lots of lift).
	Y1	Single lower Yellow Bar with no other segments indicates slowing/moderate AOA.

SEGMENT	ABBR	CONDITION
	Y2	Double Yellow Bars with no other segments indicates pattern entry/increasing AOA.
	Y3	Single upper Yellow Bar with no other segments indicates Base leg/increasing AOA.
	YB	Single upper Yellow Bar with Blue lower Half-Circle indicates Final/slightly fast.
	B	Blue Circle / Donut with no other segments indicates Optimum Alpha Angle (AOA).
	BR	Single Red Bar with Blue upper-Half-Circle with no other segments indicates slightly slow/below OAA.
	R1	Red Bar with inverted Red Chevron with no other segments indicates too slow (level 1) KLR 10 announces " Check AOA ".
	R2	Red Arrow with inverted Red Chevron with no other segments indicates too slow (level 2) and KLR 10 announces " Caution. Too Slow ".

SEGMENT	ABBR	CONDITION
	R3	Flashing Red Arrow , with no other segments indicates critical AOA (level 3) and KLR 10 announces “Too slow! Too slow!”

Note: *No Segments illuminated = Power off OR very low speed and lift state OR absence of pressure information to the interface module OR aircraft on the ground with no movement.*

2.4 DISPLAY BRIGHTNESS CALIBRATION

The KLR 10 indicator is preset at the factory for daytime/nighttime brightness levels. If the maximum/minimum brightness levels need to be changed in your aircraft, do the following procedure to preset both the daytime and nighttime display brightness levels while on the ground.

Enter the Brightness calibration mode as follows:

- Ensure that power is not applied to the KLR 10.
- Depress and hold the **Brightness button** on the KLR 10 indicator then apply power to the KLR 10.
- Continue to depress the **Brightness button** until all segments are illuminated.
- Release the Brightness button.

The system is now in Brightness calibration mode.

- With a light applied directly to the photo diode on the KLR 10 indicator for at least 5 seconds, press and release the **Brightness button** until the display is at its maximum brightness.

Cycling past the maximum brightness of the colored segments will cause the indicator to return to the minimum level. There are 16 brightness steps that are sequenced through, increasing brightness at each step.

- Wait 5 seconds for the unit to store the setting then remove the light from the KLR 10 indicator.

The display's brightness will change to the lower brightness level unless the low light setting was set to maximum brightness or the cockpit is in daylight.

- Next, cover the photo diode on the display for at least 5 seconds with your thumb or a piece of black electrical tape. Quickly press and release the **Brightness** button on the KLR 10 indicator until it's at a minimum or lowest level.
- Wait 5 seconds for the unit to store the setting then remove your thumb or the tape.

Observe that the display's brightness level changes from dim to bright when light is applied and removed from the photo diode. This process takes about 5 seconds for the brightness level to change.

- Remove power, wait a few seconds and re-apply power.

On power up, if fully calibrated, the system will enter its self test, display illumination routine in which all colored segments are illuminated one by one upwards and then one by one downwards. Otherwise, if OAA and Cruise still need to be calibrated, then the blue and green segments will flash and then turn off.

2.5 BRIGHTNESS ADJUSTMENT WHEN ACTIVE

To change brightness when the unit is active, quickly push and release the **Brightness** button until the desired brightness level is reached.

There are 16 brightness levels and a photo cell to detect “**nighttime**” and “**daytime**” ambient light levels and automatically switches to the stored level. The new brightness levels are stored when powered off.

2.6 IN-FLIGHT CALIBRATION FLOW CHARTS

The following flow charts contain an abbreviated version of the in-flight calibration procedures. The complete in-flight calibration procedures are contained in Section 5 of the KLR 10 Lift Reserve Indicator Installation Manual, part number D201305000058.

It is highly recommended, to make calibration easier and safer, that the pilot flies the aircraft while a second person follows the calibration procedure and enters the appropriate set points for the instrument.

CAUTION

At ALL times, the Pilot-in-Command must fly the aircraft in a safe manner at altitude while maneuvering the aircraft in slow flight.

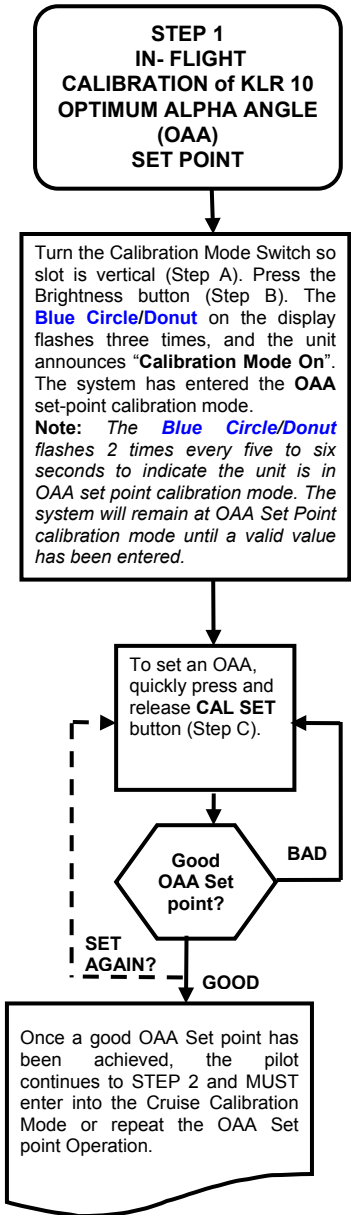

In-Flight calibration requires the pilot to climb to a safe altitude for slow flight maneuvers. The pilot will fly the aircraft to the condition of Optimum Alpha Angle (**OAA**). Aircraft is at **OAA**, when:

- 1.) Aircraft is at a safe altitude for slow flight maneuvers.
- 2.) Minimum controllable flight, lower power setting (such as a down wind or landing pattern power setting).
- 3.) Able to hold altitude, 0 Vertical Speed, **not descending, zero sink (5 to 10 fpm climb OK if your aircraft loses flight control stability at 0 VS)**.
- 4.) Full aileron, elevator and rudder control, **not in a buffet**, pilot to identify the set point by pitching back slowly to a pitch no longer able to climb but able to hold altitude with full control of the airplane.

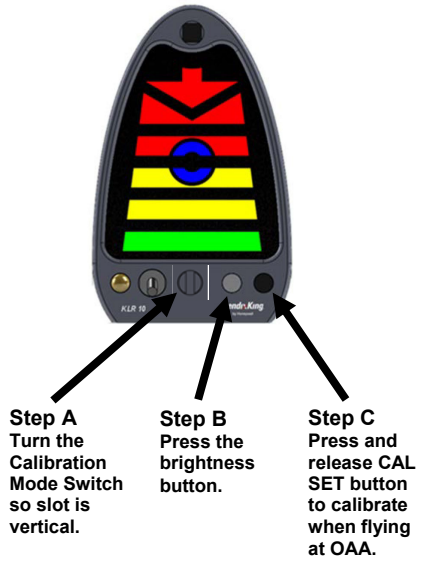

Figure 2-2: OAA Setpoint Calibration

**STEP 2
IN- FLIGHT CALIBRATION
of KLR 10 CRUISE
SET POINT**

The pilot must fly the aircraft at a "Cruise" In-flight condition, straight and level, holding altitude at Cruise power. This procedure sets the display to indicate "Cruise" AOA for the aircraft.

After the OAA set point is set successfully: Do not adjust the Calibration Mode Switch. Press the brightness button to enter the Cruise Set Point calibration mode (Step A). The KLR 10 Display flashes the **Green Bar** three times and there is no audio announcement. The system has entered the **Cruise Set point Calibration mode**.

NOTE: The **GREEN BAR** flashes 2 times every five to six seconds indicating that the unit is in Cruise Set Point calibration mode. Unit will stay in this mode until a valid cruise setting is entered and OAA and Cruise calibration mode is exited.



STEP A
Press the brightness Button. The **Green Bar** flashes three times, there is no audio announcement.

STEP B
Quickly press and release CAL SET button when flying at "Cruise".

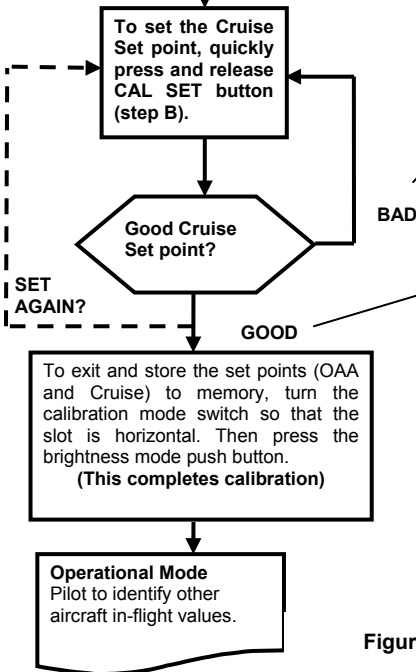

Bad Set point:

The **GREEN BAR** flashes 3 times and unit announces: "Invalid Set Point".

Good Set point:

The **GREEN BAR** is displayed and unit announces: "Cruise Alpha Calibration Set". The operator can set it again or exit calibration Mode, storing the values, putting the system in functional mode.

Note:

If the Setting is NOT Successful: The KLR 10 display returns to an operational state and discards the attempted set point (Values out of range).

AND

The KLR 10 instrument display's **Green Bar** flashes three times and announces "Invalid Set Point".

Figure 2-3: Cruise Setpoint Calibration

3. OPERATION

The KLR 10 Lift Reserve Indicator improves pilot awareness of available lift during operation at high angles of attack such as slow flight, takeoffs and landings.

The system is calibrated with the aircraft in the clean configuration. When flaps are extended, the KLR 10 AOA indications will be more conservative (showing higher AOA).

This section explains the procedures to be flown to develop a reference list that shows the segments that are lit on the KLR 10 Indicator during the different phases of flight.

Section 3.1 on page 3-2 gives the procedure to practice a high AOA flight regime with the use of the KLR 10 Indicator.

Section 3.2 on page 3-7 gives the procedures to practice takeoffs and climb outs with the use of the KLR 10 Indicator.

Section 3.3 on page 3-11 gives the procedures to maintain best glide speed with the use of the KLR 10 Indicator.

Section 3.4 on page 3-13 gives the procedures to practice approaches with the use of the KLR 10 Indicator.

3.1 PRACTICE HIGH AOA FLIGHT REGIME

To familiarize you with the **KLR 10** indications during a high AOA flight regime, use the following outline as a guide:

- Plan a flight to an area where high AOA flight can be performed without any undue hazards (reference § 91.303 & § 91.305).
- Review the stall recovery procedures for your aircraft. If an inadvertent stall occurs, immediately recover from the stall per your training and the aircraft manufacturers instructions. At no time is a stall required to correctly calibrate or operate the KLR 10.
- Acquaint yourself with the KLR 10 indicator and its functions.
- Preflight and operate the aircraft as you would normally.
- When in an area and at a safe altitude that safe operation at slow flight can be performed and the air is smooth, perform clearing turns to ensure the area is clear.
- Follow the aircraft procedures and slow the aircraft, in the clean configuration (No Flaps).
- Maintain coordination.
- Maintain altitude.
- Monitor the KLR 10 indicator.
- Slow to just above the stall. If any stall warning device activates or an impending aerodynamic stall is imminent, recover immediately using the appropriate procedure for your aircraft.
- Return to normal flight.
- Using the abbreviations from Table 2-2 on page 2-4, write down the illuminated segments in the space provided below and in the Table 3-1: Observed Indications Chart on page 3-17.

Observed Indications

As the aircraft slows and the AOA increases, note the following:



The colored segments on the AOA indicator transitions from the **Green Bar (G)** segment (Cruise) up through to the **flashing Red arrow (R3)** segment.



A “**Check AOA**” warning annunciates as the AOA increases and the **Red Bar with inverted Red Chevron (R1)** segment is displayed.



A “**Caution, Too Slow**” warning annunciates when the AOA increases more and the **Red Arrow with inverted Red Chevron (R2)** segment is displayed.



Start your recovery from the high AOA flight regime when the “**Too slow! Too slow!**” warning annunciates and the **flashing Red arrow** is displayed.

Note: If any stall warning device activates or an impending aerodynamic stall is imminent, recover immediately using the appropriate procedure for your aircraft.

As the recovery progresses:

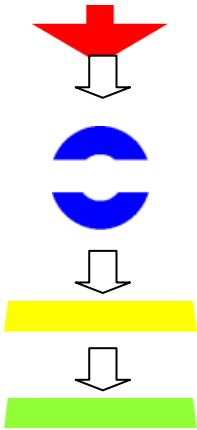

The AOA indicator transitions from the **flashing Red Arrow** segment through the **Blue Circle (B)** segment and continues through the **Yellow Bars (Y2)** segment until finally the **Green Bar (G)** segment (Cruise) is illuminated.

Follow the outline above again but perform the high AOA flight regime in the landing configuration (dirty) and observe the following:

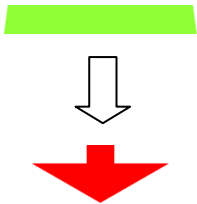

The colored segments on the AOA indicator transitions from the **Green Bar (G)** segment (Cruise) up through to the **flashing Red Arrow (R3)** segment.



A “**Check AOA**” warning annunciates as the AOA increases and the **Red Bar with inverted Red Chevron (R1)** segment is displayed.



A “**Caution, Too Slow**” warning annunciates when the AOA increases more and the **Red Bar with inverted Red Chevron (R2)** segment is displayed.



Start your recovery from the high AOA flight regime when the “**Too slow! Too slow!**” warning annunciates and the **flashing Red arrow** is displayed.

Note: If any stall warning device activates or an impending aerodynamic stall is imminent, recover immediately using the appropriate procedure for your aircraft.

As the recovery progresses:

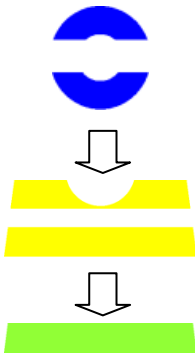

The AOA indicator transitions through the **blue circle** segment, **Yellow Bars** segment, to finally the **Green Bar** segment (cruise, lots of lift).

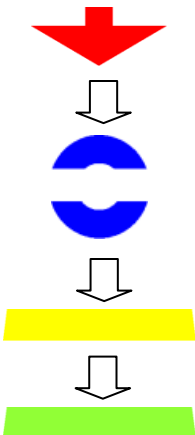

The lower the segments, from **flashing Red Arrow** (R3) segment, **Blue Circle** (B) segment, **Yellow Bar** (Y1) segment and to the **Green Bar** (G) segment, the more the lift (lower AOA).

Increasing

Lift



Practice until you become familiar with the indications on the AOA and the relationship of your airspeed indicator. Since the airfoil on your aircraft will **ALWAYS** stall at the same AOA (**regardless of weight**) the AOA indications will be the same every time.

3.2 PRACTICE TAKEOFF AND CLIMB USING AOA

The use of AOA for takeoff and climb performance will greatly increase the pilot's awareness while operating at high angles of attack and yield safe and consistent results.

For example, if you intend to perform a short field over an obstacle takeoff there are a number of factors you must consider to arrive at the proper indicated airspeed for the climb. Changing gross weight, pressure, altitude and temperature will all have an effect on the indicated climb speed. On the other hand, once you establish the correct AOA for the climb, it will be the same regardless of the factors previously mentioned.

To determine the correct AOA for a climb we need a baseline to start from. For this example we will figure it out for V_x (best angle of climb). Some aircraft may use two different speeds based on the aircraft configuration, let's use the one for clearing an obstacle on takeoff. Refer to the aircraft manual to determine the configuration and airspeed for V_x considering the following factors:

- Identify actual gross weight.
- Pressure altitude, at the demonstration altitude.
- Temperature, at the demonstration altitude.
- Correct Calibrated Air Speed (CAS) for installation errors to arrive at Indicated Air Speed (IAS).

Establish Segments Illuminated

As before, to familiarize you with the KLR 10 indications for V_x use the following outline as a guide:

- Plan a flight to an area where the desired maneuvers may be performed without any undue hazards.
- Acquaint yourself with the KLR 10 indicator.
- Preflight and operate the aircraft as you would normally.
- When in the area, perform clearing turns to ensure the area is clear.
- Maintain coordination and altitude.
- Use power to slow and configure for V_x .
- Maintain the indicated airspeed for V_x .
- Observe the KLR 10 AOA indication and make a mental note.
- Return to normal flight.
- Using the abbreviations from Table 2-2 on page 2-4, write down the illuminated segments in the space provided below and in the Table 3-1: Observed Indications Chart on page 3-17.

Segments Illuminated:

This AOA indication is accurate for future use at any gross weight or altitude, **every time**. Also, this same method may be used to determine the AOA for any climb. Now try it for V_y , best rate of climb, using the procedure described above.

Fly Practice Takeoffs for Familiarization

Now practice the use of the AOA for takeoff at airports that give you a comfortable margin. Then when you perfect the technique you can perform short field over an obstacle takeoffs safely. Use the following outline as a guide.

- Review your aircraft procedures for short field over an obstacle takeoff.
- Plan for a flight at an airport where normal takeoffs and landing may be performed.
- Preflight and operate the aircraft as you would normally.
- Perform the takeoff run as specified in the aircraft manual.
- At the specified takeoff speed, rotate smoothly to the AOA for V_x .

CAUTION

Do not over rotate or rotate too rapidly as either will cause catastrophic results.

- When well above the obstacle, decrease the AOA and clean up on schedule.
- Adjust the pitch to achieve the AOA for V_y and continue the climb.
- Return to normal flight.
- Using the abbreviations from Table 2-2 on page 2-4, write down the illuminated segments in the space provided below and in the Table 3-1: Observed Indications Chart on page 3-17.

Segments Illuminated:

Observed Indications

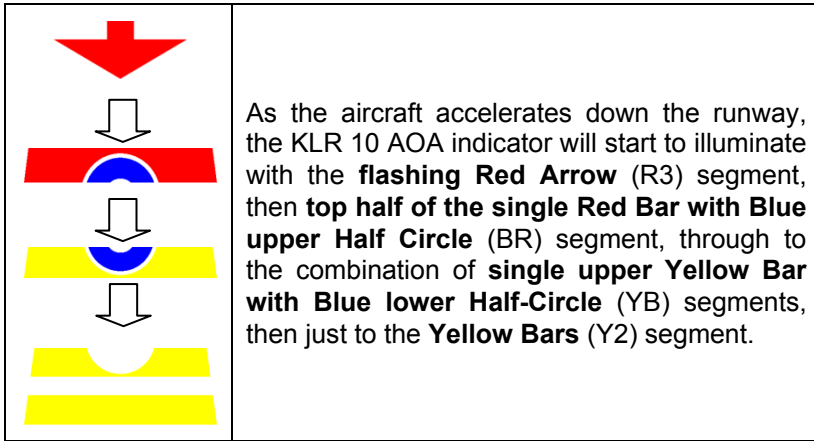

When the pitch is rotated up, the AOA indication will move towards **V_x**. Adjust the pitch to maintain the **V_x** angle.

To accelerate and clean up, the pitch is lowered, thus lowering the AOA, decreasing induced drag and increasing lift. This allows the aircraft to accelerate so the flaps can be retracted and the changes in AOA can be observed.

3.3 PRACTICE BEST GLIDE SPEED

As mentioned earlier, the AOA may be used for identifying aircraft performance based on a fixed AOA or a constant CL. For this discussion CL/CD Maximum indication will be identified. This is the maximum lift-to-drag ratio at which maximum range and maximum glide distance will be found for propeller airplanes.

To find the AOA for best glide, calculate an indicated airspeed considering:

- Actual gross weight.
- Pressure altitude, at the demonstration altitude.
- Temperature, at the demonstration altitude.
- Correct CAS for installation errors to arrive at IAS.

Establish Segments Illuminated

As before, to familiarize you with the KLR 10 AOA indications for CL/CD Maximum, use the following outline as a guide:

- Plan a flight to an area where the desired maneuvers may be performed without any undue hazards.
- Acquaint yourself with the KLR 10 display AOA indicator.
- Preflight and operate the aircraft as you would normally.
- When in the area, perform clearing turns to ensure the area is clear.
- Maintain coordination.
- Maintain altitude.
- Use power to slow and maintain best glide speed.
- Observe the KLR 10 display AOA indication; this is CL/CD Maximum.
- Return to normal flight.
- Using the abbreviations from Table 2-2 on page 2-4, write down the illuminated segments in the space provided below and in the Table 3-1: Observed Indications Chart on page 3-17.

Segments Illuminated:

This AOA indication will be correct for future use at any gross weight and/or altitude, **every time**. Document the angles of attack by the segments illuminated in a permanent record for future use.

Example: Best Glide =  single upper Yellow Bar with Blue lower Half Circle (YB) segment being illuminated.

The methods used to arrive at this AOA indication are the same for all constant AOA or CL maneuvers.

3.4 PRACTICE APPROACHES USING AOA

A rule of thumb is to use an approach speed of 1.3 times the power off stall speed in the landing configuration. Another rule of thumb is in gusty winds add 5kts for one passenger and if it's really gusty add 10kts for several passengers. While flying the approach at higher speeds seems to be safer, having additional speed and kinetic energy on a short runway may not be in the best interest of said passengers. With the means to accurately know and control the AOA you can fly a more stable approach and land with less kinetic energy for any given situation than flying arbitrary approach speeds. Flying an approach and landing using an AOA indicator may be a safer procedure.

The AOA has been calibrated for an AOA just slightly less than CLMAX; however an acceptable margin above that angle to fly approach and landings has not been determined. As a starting point, use the aircraft manual to determine the stall speed of the aircraft at the **actual gross weight** in the landing configuration. Take that calibrated airspeed and multiply it by 1.3, 1.2 and 1.1. Then refer to the airspeed correction chart to determine the correction, if any, to convert from calibrated airspeed to indicated airspeed for the three speeds. For example:

Calibrated Stall Speed X 1.3 = App. CAS ± the correction = App. IAS

58 kts CAS X 1.3 = 75.4 kts CAS + 2 kts correction = 77 kts IAS

58 kts CAS X 1.2 = 69.6 kts CAS + 3 kts correction = 73 kts IAS

58 kts CAS X 1.1 = 63.8 kts CAS + 4 kts correction = 68 kts IAS

For ease of discussion, let's call these speeds and the resulting AOA indication as 3, 2 and 1 respectively. Once the AOA angles have been identified, they will be **accurate at any gross weight, every time.**

Establish Segments Illuminated

To establish the AOA indications for approaches, use the following outline as a guide:

- Plan a flight to an area where approaches and slow flight can be performed without any undue hazards (reference § 91.303 & § 91.305).
- Review the stall recovery procedures for your aircraft in case of an inadvertent stall. If an inadvertent stall occurs, immediately recover from the stall per your training and the aircraft manufacturer's instructions. At no time is a stall required to correctly calibrate or operate the KLR 10.
- Acquaint yourself with the KLR 10 display AOA indicator.
- Preflight and operate the aircraft as you would normally.
- When in an area where approaches and slow flight can be performed and the air is smooth, perform clearing turns to ensure the area is clear.
- Follow the aircraft procedures, slow and configure to the landing configuration.
- Maintain coordination.
- Maintain altitude with the pitch (use pitch trim to relieve back pressure).
- Use power as needed to maintain flight at the first of the calculated approach speeds, “**3**”.
- Write down the colored segments illuminated. _____
- Use power as needed to slow to and maintain flight at the second of the calculated approach speeds, “**2**”.
- Write the new segments illuminated. _____
- Use power as needed to slow to and maintain flight at the third of the calculated approach speeds, “**1**”.
- Return to normal flight.
- Write the new segments illuminated. _____
- Write the segments illuminated for the 3 approaches in the Table 3-1: Observed Indications Chart on page 3-17.

Fly Practice Approaches for Familiarization

To familiarize you with the aircraft while flying practice approaches using the KLR 10 Indicator as a guide, please use the following outline:

- Plan a flight to an area where approaches and slow flight can be performed without any undue hazards (reference § 91.303 & § 91.305).
- Review the stall recovery procedures for your aircraft.
- Acquaint yourself with the KLR 10 indicator.
- Preflight and operate the aircraft as you would normally.
- When in an area where approaches and slow flight can be performed and the air is smooth, perform clearing turns to ensure the area is clear.
- Follow the aircraft procedures, slow and configure to the landing configuration.
- Maintain coordination.
- Set the power as you would to fly a normal approach.
- Maintain altitude with the pitch until the AOA approaches the “3” indication. Lower and use pitch to maintain that AOA (use pitch trim to relieve back pressure).
- Fly the aircraft in the descent (straight & turning), pay attention to the flight control effectiveness.
- Perform a recovery from the high AOA condition prior to any aerodynamic or aural/visual stall warning using the manufacturer’s instructions for your aircraft.
- Climb back to the initial altitude.

Repeat the steps above using AOA indications “2” and “1”. Gain experience by practicing these simulated approaches and landings using the AOA indicator.

Some notable observations:

- The control effectiveness decreases with higher AOA.
- The higher the AOA, the more attention has to be given to rudder inputs to compensate for adverse yaw.
- Approaches at the higher angles of attack leaves little time between starting the flair and stall.









Useful Techniques when using KLR 10 Indicator

Some techniques and things to consider when using the KLR 10 Indicator to fly approaches are:

- Coordinate the use of pitch and power to fly the approach and landing.
- Use **PITCH** primarily to control the AOA.
- Use **POWER** primarily to control the descent rate.
- Keep in mind how much power it took to just maintain altitude.
- A stable approach all the way to the runway is much safer than making radical changes to the AOA or descent rate once an obstacle is cleared.
- Set a safe standard for yourself using all your experience to set a maximum AOA for any approach and do not let pressures cause you to fly an approach at too high of AOA.
- When flying in gusty conditions fly a lower AOA so that when a wind gust changes your AOA it does not exceed **your maximum AOA**.
- Having a great new system to indicate AOA does **NOT** change the laws of physics, use it as a new tool to fly safe.

Write down the actual indications you observe on the KLR 10 Indicator as you conduct the different phases of flight.

Table 3-1: Observed Indications Chart

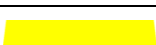
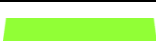
Segment Illuminated	ABBR	Phase of Flight	Flaps Up (Clean)	Flaps Down (Dirty)
	R3	High AOA (pre-stall)		
	R2	Climb Vx		
	R1	Climb Vy		
	BR	Cruise		
	B	Best Glide Speed		
	YB	Approaches		
	Y3	1.3 Vs		
	Y2	1.2 Vs		
	Y1	1.1 Vs		
	G			

4. APPENDIX

4.1 ACRONYMS AND ABBREVIATIONS

Acronyms and abbreviations used in this manual are defined as follows:

TERMS	DEFINITION
AOA	Angle of Attack
CAS	Calibrated Air Speed
CL	Coefficient of Lift
CLmax	Coefficient of Lift Maximum
Cd	Coefficient of Drag
CL/Cd	Coefficient of Lift over Coefficient of Drag
FAA	Federal Aviation Administration
IF module	Interface Module
IA	Inspection Authorization
IAS	Indicated Air Speed
kts	Nautical miles per hour
MAC	Mean Aerodynamic Cord ()
OAA	Optimum Alpha Angle
Vs	Stall Speed – clean
Vx	Speed that allows for best angle of climb

TERMS	DEFINITION
Vy	Speed that allows for the best rate of climb

4.2 COPYRIGHT - NOTICE

Copyright 2013, 2014, Honeywell International Inc. All rights reserved.

Honeywell is a registered trademark of Honeywell International Inc.

All other marks are owned by their respective companies.